

GGX02 SYSTEM

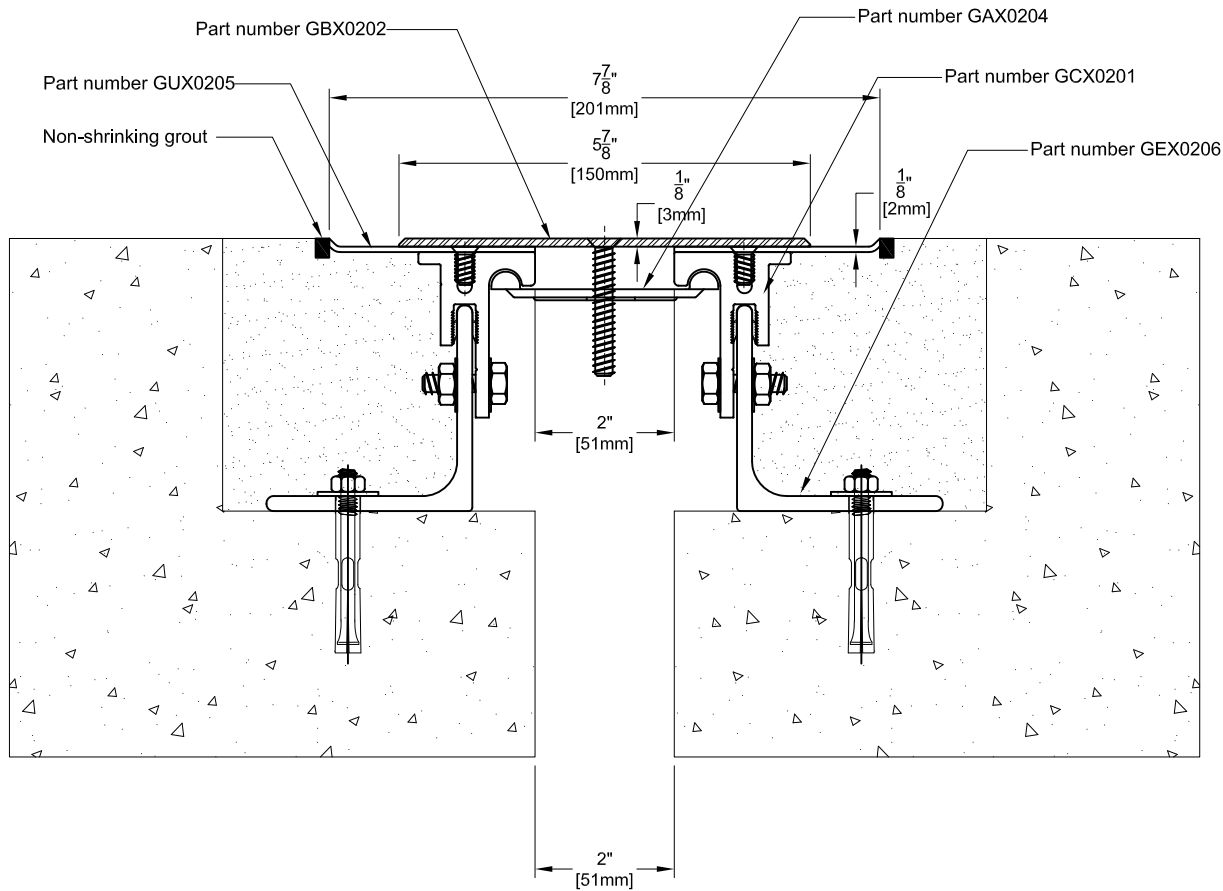

TECHNICAL DATA	IMPERIAL (inc)	METRIC (mm)
Joint Width	2"	51
Movement ± (Horizontal)	1"	25
Movement ± (Vertical)	1"	25
Load:	3.5 (Tons)	
Date: May., 2013	Scale: NTS	
Rev:	Drawn by: NP	

APPLICATION: Expansion Joint Cover for Floor to Floor Condition (Heavy Duty)



PROSPEC SPECIALTIES INC.
 3601 HIGHWAY 7, SUITE 400
 MARKHAM ON L3R 0M3, CANADA.
 TEL: (888) - 749 - 8456,
 FAX: (888) - 749 - 8455
 Email: info@prospecspecialties.com
 Web: prospecspecialties.com

Disclaimer: As Prospec Specialties' Policy is one of continual technical progress for the improvement of the company's services to its customers, the company reserves the right to modify the Designs of its products without notice.

GGX03 SYSTEM

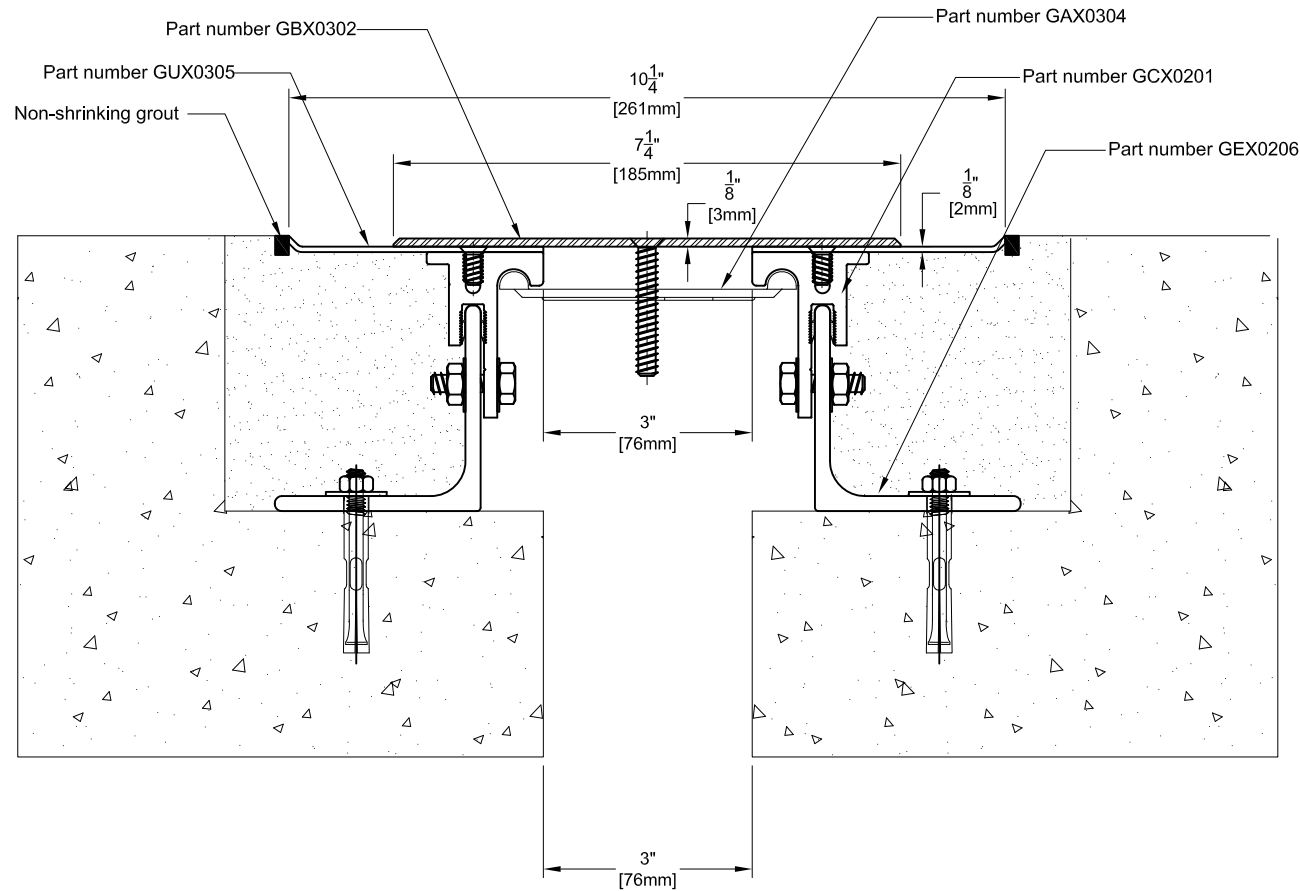

TECHNICAL DATA	IMPERIAL (inc)	METRIC (mm)
Joint Width	3"	76
Movement \pm (Horizontal)	1-1/2"	38
Movement \pm (Vertical)	1-1/2"	38
Load:	3.5 (Tons)	
Date: May., 2013	Scale: NTS	
Rev:	Drawn by: NP	

APPLICATION: Expansion Joint Cover for Floor to Floor Condition (Heavy Duty)



PROSPEC SPECIALTIES INC.
 3601 HIGHWAY 7, SUITE 400
 MARKHAM ON L3R 0M3, CANADA.
 TEL: (888) - 749 - 8456,
 FAX: (888) - 749 - 8455
 Email: info@prospecspecialties.com
 Web: prospecspecialties.com

Disclaimer: As Prospec Specialties' Policy is one of continual technical progress for the improvement of the company's services to its customers, the company reserves the right to modify the Designs of its products without notice.

GGX04 SYSTEM

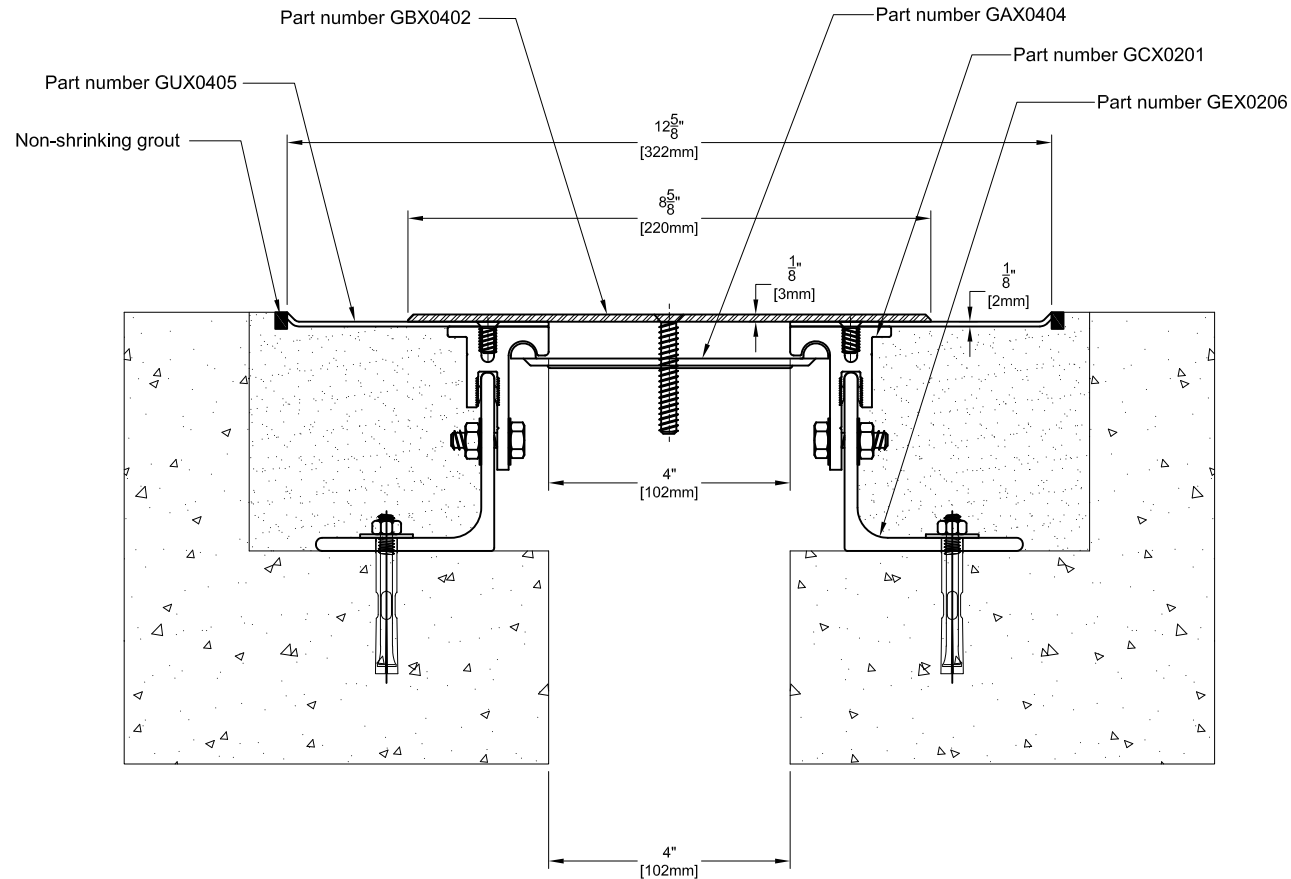

TECHNICAL DATA	IMPERIAL (inc)	METRIC (mm)
Joint Width	4"	102
Movement ± (Horizontal)	2"	51
Movement ± (Vertical)	2"	51
Load:	3.5 (Tons)	
Date: May., 2013	Scale: NTS	
Rev:	Drawn by :	NP

APPLICATION: Expansion Joint Cover for Floor to Floor Condition (Heavy Duty)



PROSPEC SPECIALTIES INC.
 3601 HIGHWAY 7, SUITE 400
 MARKHAM ON L3R 0M3, CANADA.
 TEL: (888) - 749 - 8456,
 FAX: (888) - 749 - 8455
 Email: info@prospecspecialties.com
 Web: prospecspecialties.com

Disclaimer: As Prospec Specialties' Policy is one of continual technical progress for the improvement of the company's services to its customers, the company reserves the right to modify the Designs of its products without notice.

GGX06 SYSTEM

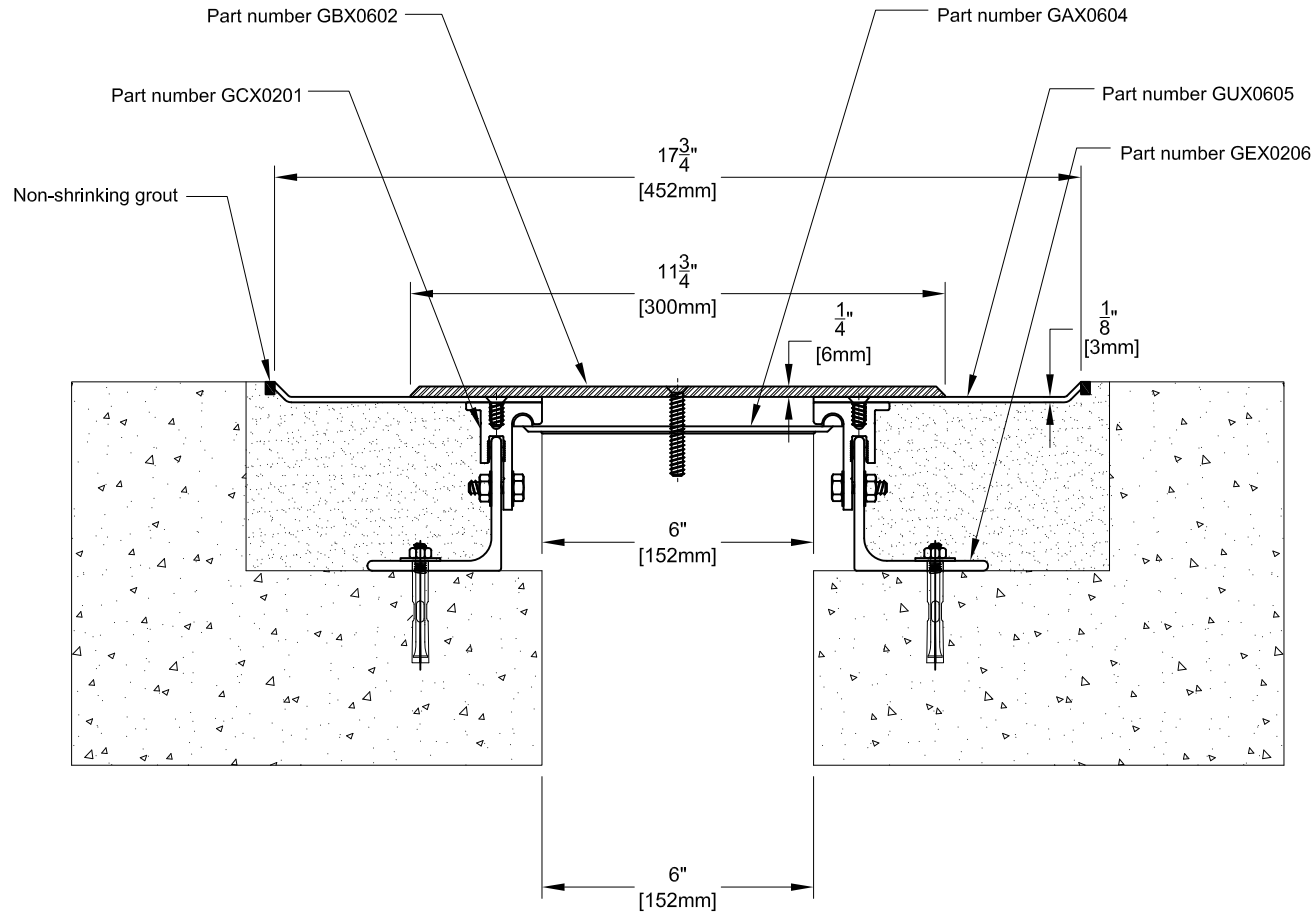

TECHNICAL DATA	IMPERIAL (inc)	METRIC (mm)
Joint Width	6"	152
Movement ± (Horizontal)	3"	76
Movement ± (Vertical)	3"	76
Load:	3 (Tons)	
Date: May., 2013	Scale: NTS	
Rev:	Drawn by: NP	

APPLICATION: Expansion Joint Cover for Floor to Floor Condition (Heavy Duty)



PROSPEC SPECIALTIES INC.
 3601 HIGHWAY 7, SUITE 400
 MARKHAM ON L3R 0M3, CANADA.
 TEL: (888) - 749 - 8456,
 FAX: (888) - 749 - 8455
 Email: info@prospecspecialties.com
 Web: prospecspecialties.com

Disclaimer: As Prospec Specialties' Policy is one of continual technical progress for the improvement of the company's services to its customers, the company reserves the right to modify the Designs of its products without notice.

GGX08 SYSTEM

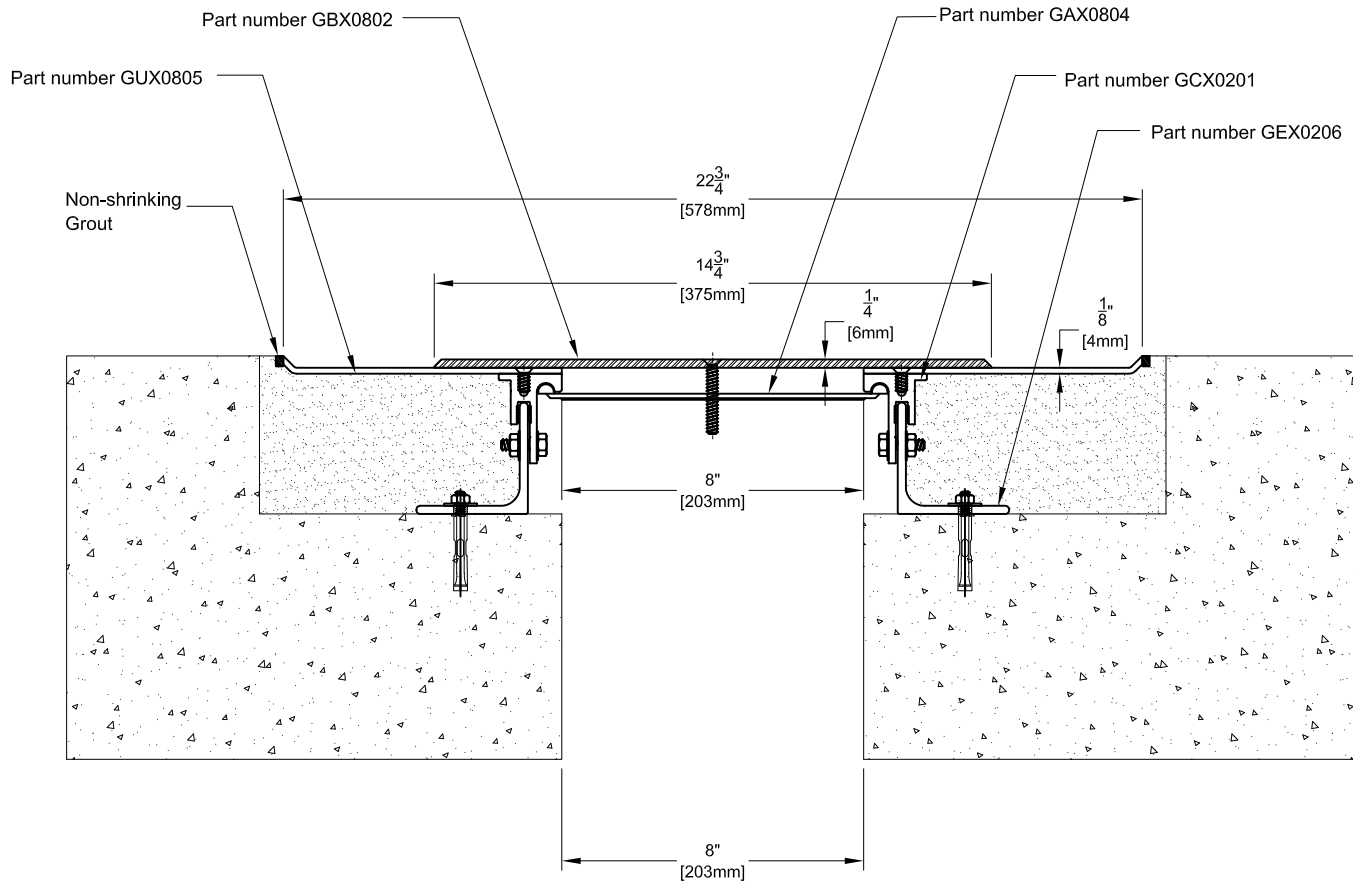

TECHNICAL DATA	IMPERIAL (inc)	METRIC (mm)
Joint Width	8"	203
Movement ± (Horizontal)	4"	102
Movement ± (Vertical)	4"	102
Load:	3 (Tons)	
Date: May., 2013	Scale: NTS	
Rev:	Drawn by: NP	

APPLICATION: Expansion Joint Cover for Floor to Floor Condition (Heavy Duty)



PROSPEC SPECIALTIES INC.
 3601 HIGHWAY 7, SUITE 400
 MARKHAM ON L3R 0M3, CANADA.
 TEL: (888) - 749 - 8456,
 FAX: (888) - 749 - 8455
 Email: info@prospecspecialties.com
 Web: prospecspecialties.com

Disclaimer: As Prospec Specialties' Policy is one of continual technical progress for the improvement of the company's services to its customers, the company reserves the right to modify the Designs of its products without notice.

GG510 SYSTEM

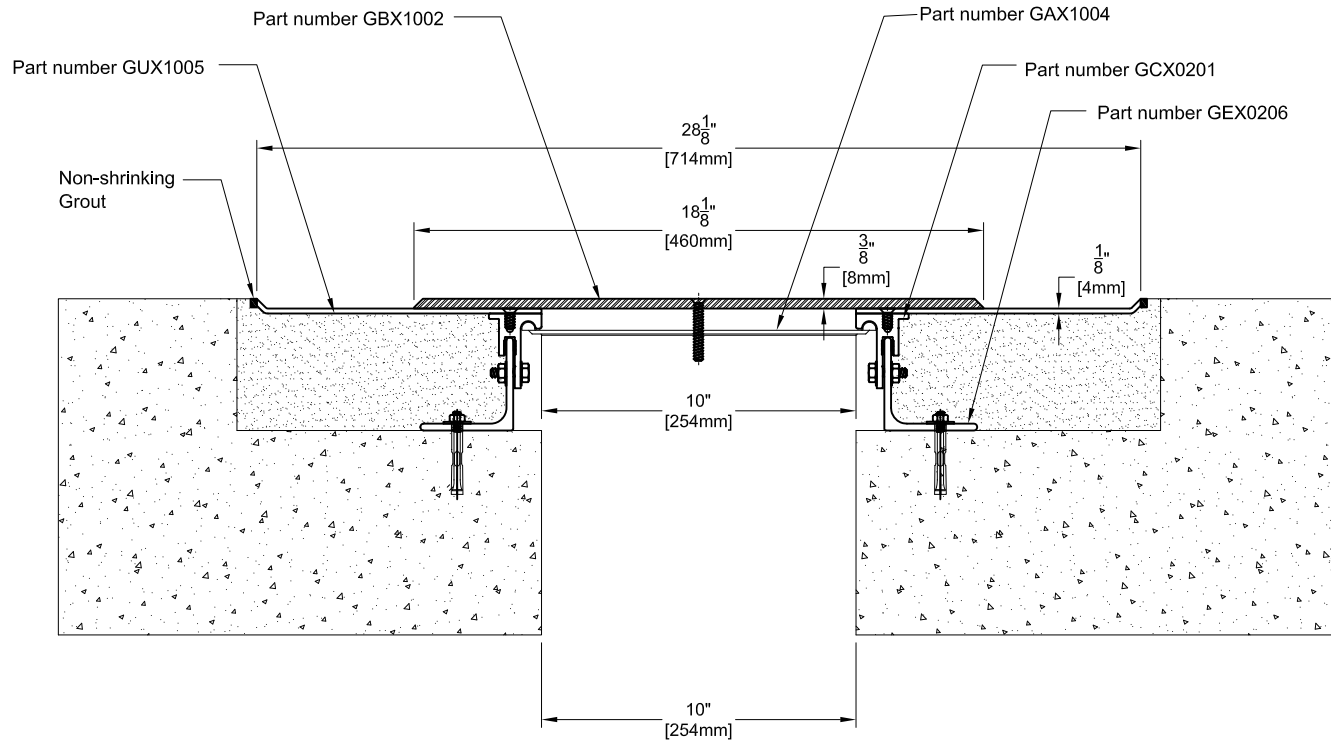

TECHNICAL DATA	IMPERIAL (inc)	METRIC (mm)
Joint Width	10"	254
Movement ± (Horizontal)	5"	127
Movement ± (Vertical)	5"	127
Load:	3 (Tons)	
Date: May., 2013	Scale: NTS	
Rev:	Drawn by: NP	

APPLICATION: Expansion Joint Cover for Floor to Floor Condition (Heavy Duty)



PROSPEC SPECIALTIES INC.
 3601 HIGHWAY 7, SUITE 400
 MARKHAM ON L3R 0M3, CANADA.
 TEL: (888) - 749 - 8456,
 FAX: (888) - 749 - 8455
 Email: info@prospecspecialties.com
 Web: prospecspecialties.com

Disclaimer: As Prospec Specialties' Policy is one of continual technical progress for the improvement of the company's services to its customers, the company reserves the right to modify the Designs of its products without notice.

GG512 SYSTEM

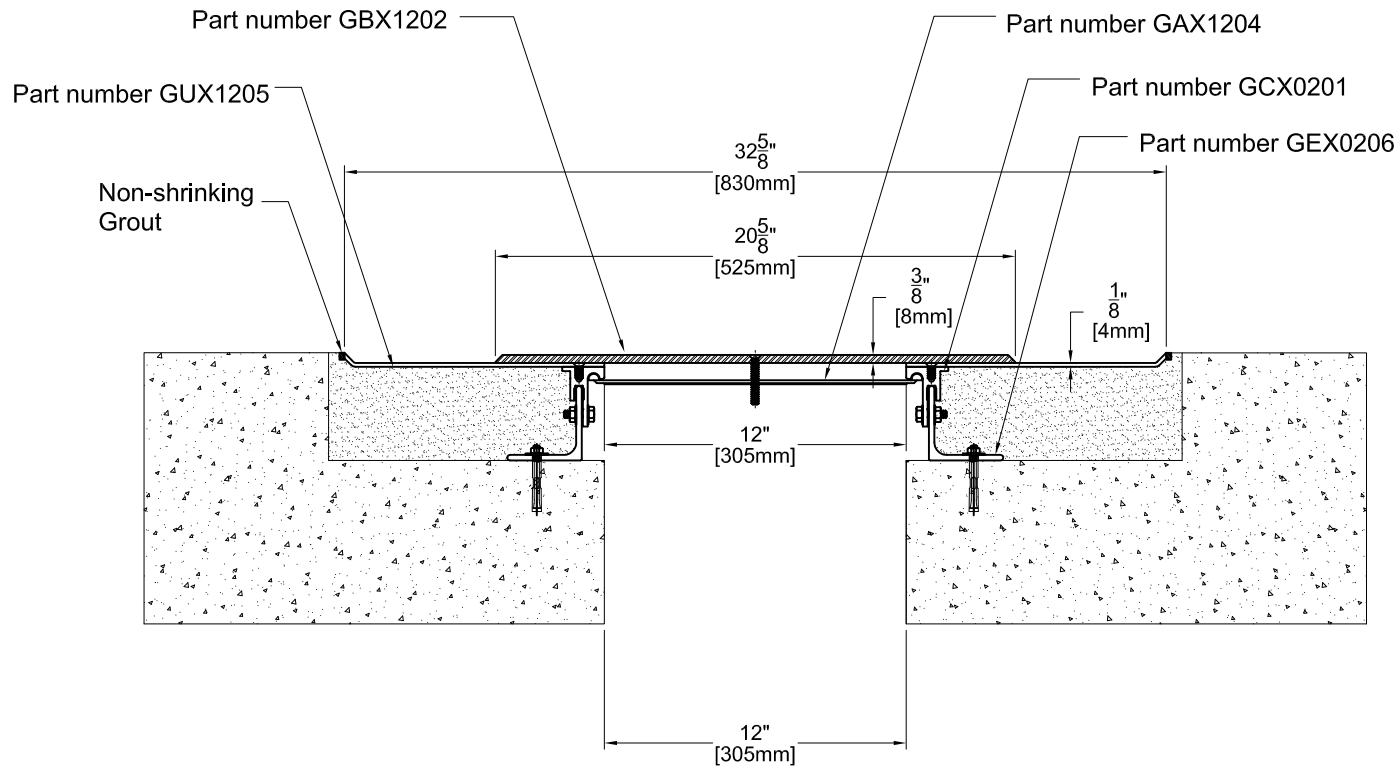

TECHNICAL DATA	IMPERIAL (inc)	METRIC (mm)
Joint Width	12"	305
Movement ± (Horizontal)	6"	152
Movement ± (Vertical)	6"	152
Load:	3 (Tons)	
Date: May., 2013	Scale: NTS	
Rev:	Drawn by : NP	

APPLICATION: Expansion Joint Cover for Floor to Floor Condition (Heavy Duty)



PROSPEC SPECIALTIES INC.
 3601 HIGHWAY 7, SUITE 400
 MARKHAM ON L3R 0M3, CANADA.
 TEL: (888) - 749 - 8456,
 FAX: (888) - 749 - 8455
 Email: info@prospecspecialties.com
 Web: prospecspecialties.com

Disclaimer: As Prospec Specialties' Policy is one of continual technical progress for the improvement of the company's services to its customers, the company reserves the right to modify the Designs of its products without notice.