

FTS01 SYSTEM

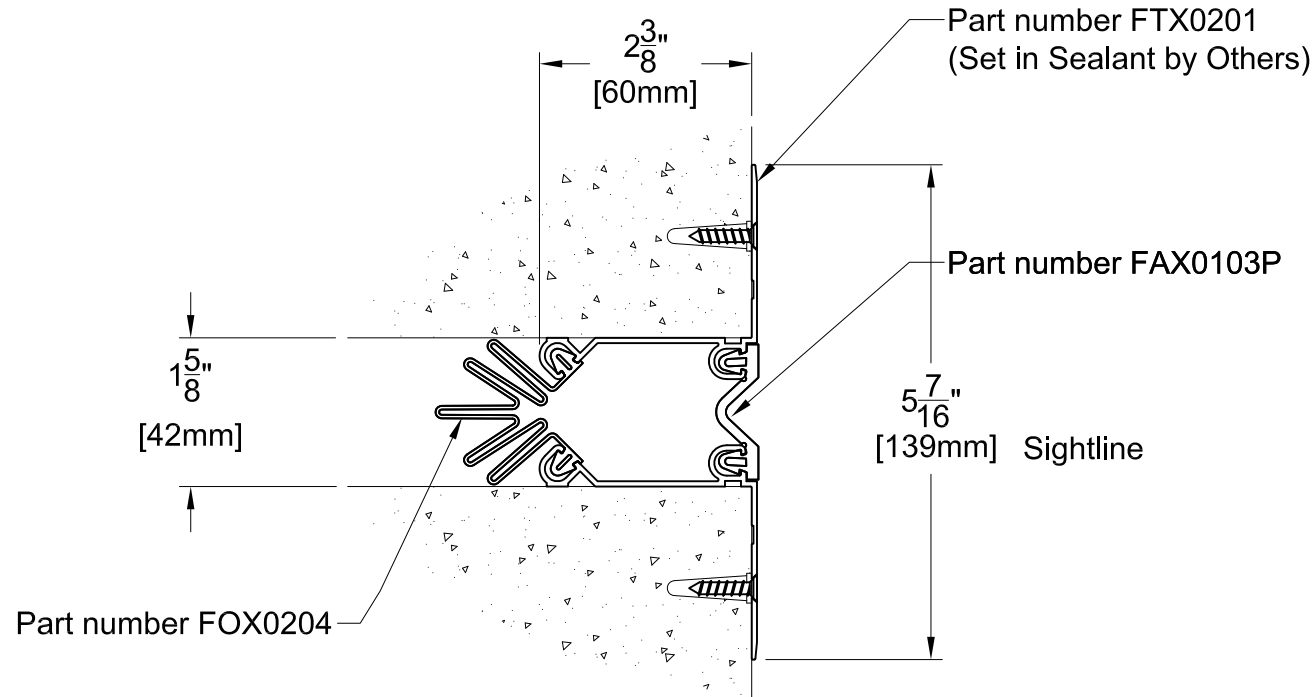

TECHNICAL DATA	IMPERIAL (in)	METRIC (mm)
Joint Width	1"	25
Movement ± (Horizontal)	1/2"	13
Movement ± (Vertical)	1/2"	13

Date: Jan., 2012 Scale: NTS

Rev: Drawn by :

Application: Expansion Joint Cover for Wall-to Wall / Ceiling to Ceiling



PROSPEC SPECIALTIES INC.
 3601 HIGHWAY 7, SUITE 400
 MARKHAM ON L3R 0M3, CANADA.
 Tel: (888) - 749 - 8456,
 Fax: (888) - 749 - 8455
 Email: info@prospecspecialties.com
 Web: prospecspecialties.com

Disclaimer: As Prospec Specialties' Policy is one of continual technical progress for the improvement of the company's services to its customers, the company reserves the right to modify the Designs of its products without notice.

FTS02 SYSTEM

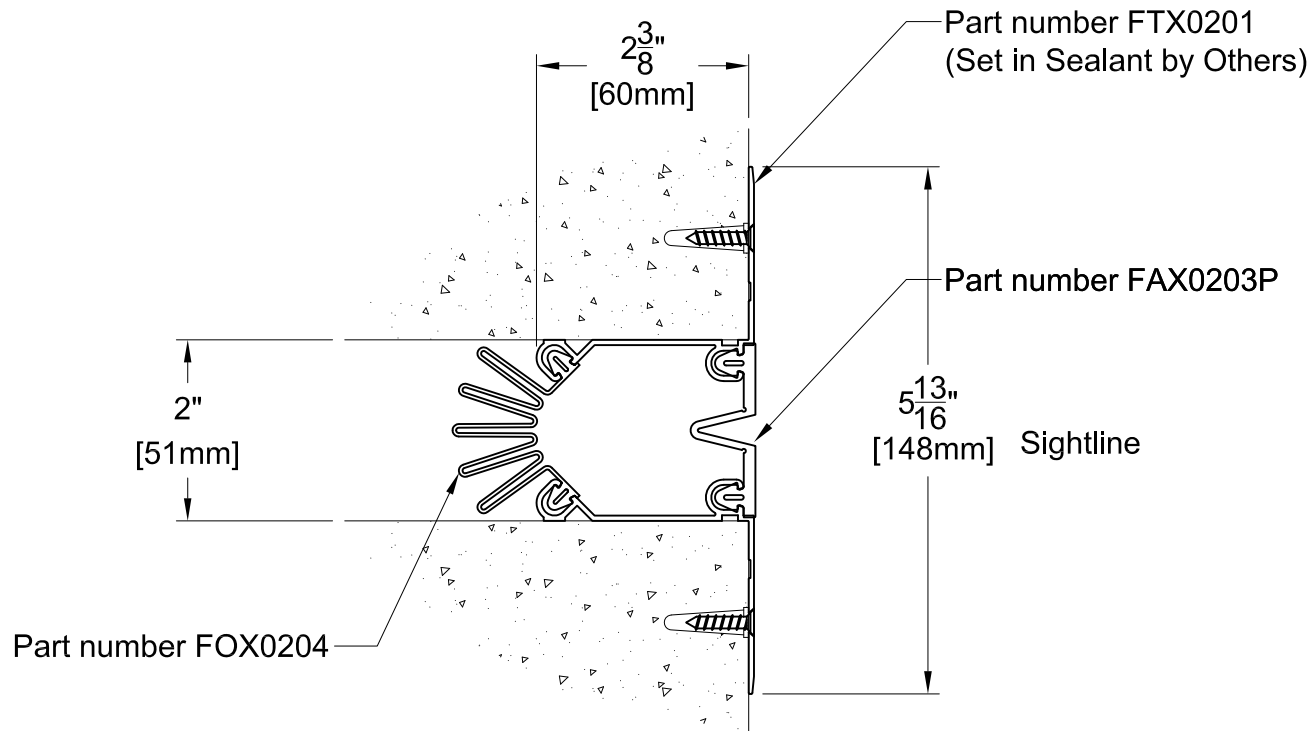

TECHNICAL DATA	IMPERIAL (in)	METRIC (mm)
Joint Width	2	51
Movement ± (Horizontal)	1"	25
Movement ± (Vertical)	1"	25

Date: Jan., 2012 Scale: NTS

Rev: 01 Drawn by :

Application: Expansion Joint Cover for Wall-to Wall / Ceiling to Ceiling



PROSPEC SPECIALTIES INC.
 3601 HIGHWAY 7, SUITE 400
 MARKHAM ON L3R 0M3, CANADA.
 Tel: (888) - 749 - 8456,
 Fax: (888) - 749 - 8455
 Email: info@prospecspecialties.com
 Web: prospecspecialties.com

Disclaimer: As Prospec Specialties' Policy is one of continual technical progress for the improvement of the company's services to its customers, the company reserves the right to modify the Designs of its products without notice.

FTS03 SYSTEM

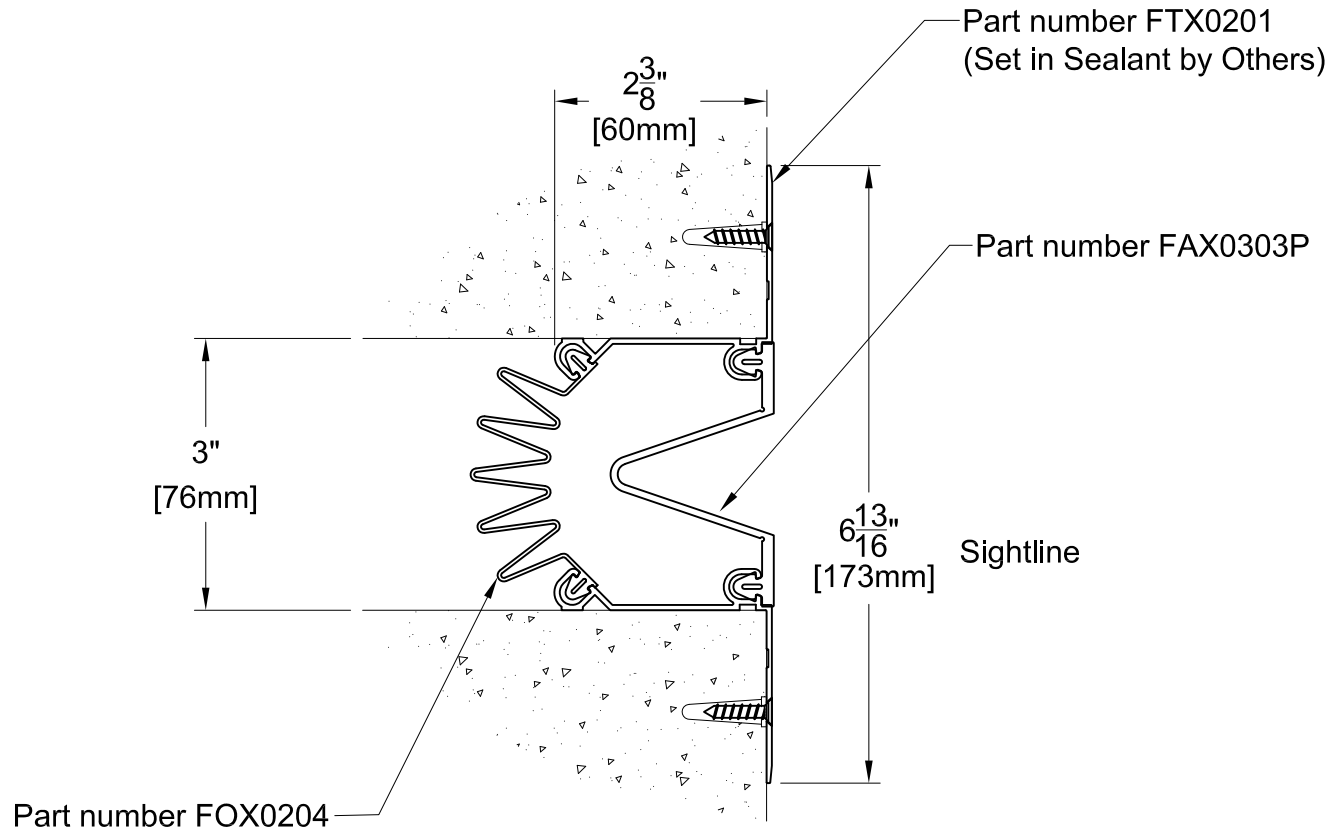

TECHNICAL DATA	IMPERIAL (in)	METRIC (mm)
Joint Width	3	76
Movement ± (Horizontal)	1-1/2"	38
Movement ± (Vertical)	1-1/2"	38

Date: Jan., 2012	Scale: NTS
Rev: 01	Drawn by :

Application: Expansion Joint Cover for Wall-to Wall / Ceiling to Ceiling



PROSPEC SPECIALTIES INC.
 3601 HIGHWAY 7, SUITE 400
 MARKHAM ON L3R 0M3, CANADA.
 Tel: (888) - 749 - 8456,
 Fax: (888) - 749 - 8455
 Email: info@prospecspecialties.com
 Web: prospecspecialties.com

Disclaimer: As Prospec Specialties' Policy is one of continual technical progress for the improvement of the company's services to its customers, the company reserves the right to modify the Designs of its products without notice.

FTS04 SYSTEM

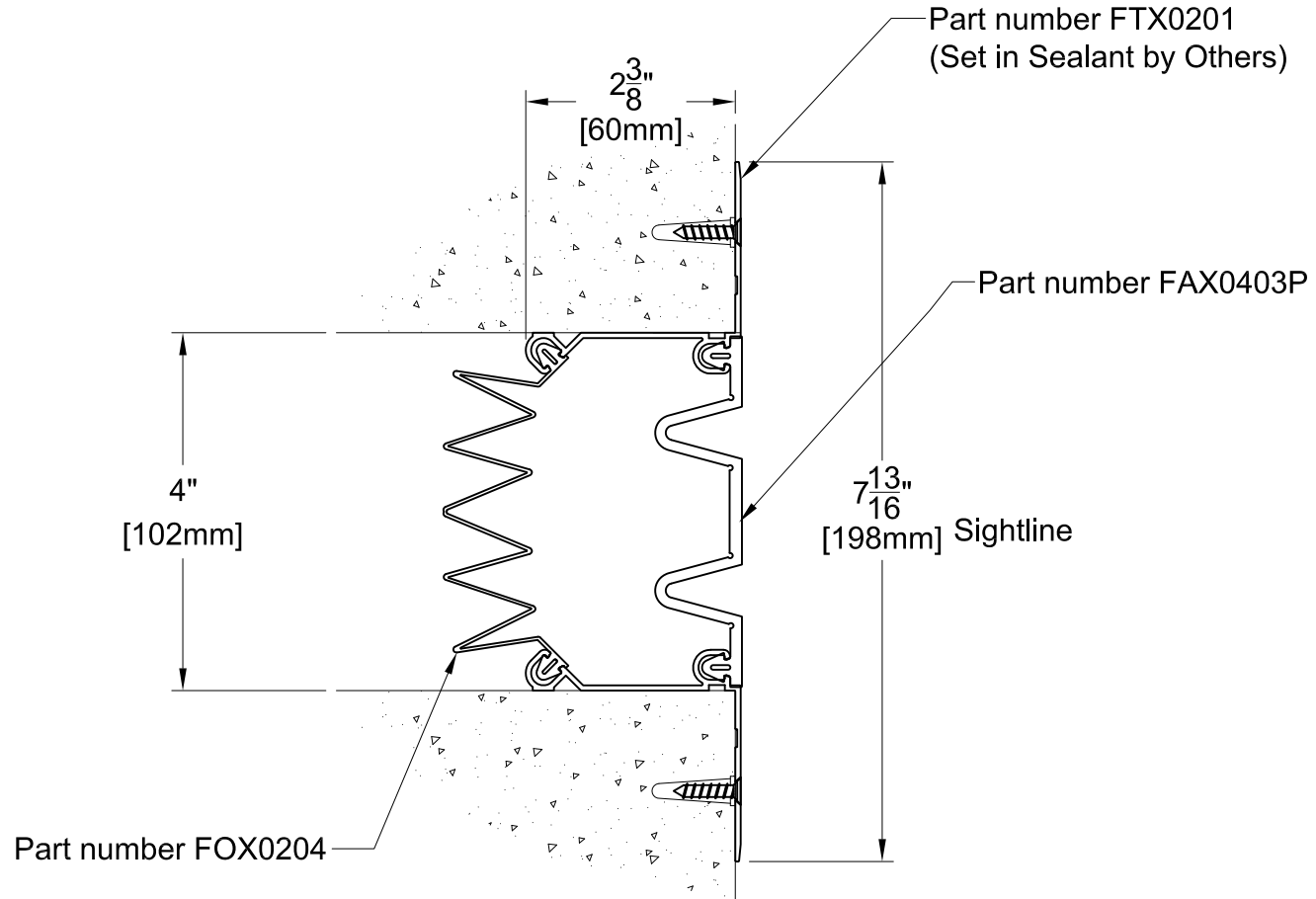

TECHNICAL DATA	IMPERIAL (in)	METRIC (mm)
Joint Width	4	102
Movement ± (Horizontal)	2"	51
Movement ± (Vertical)	2"	51

Date: Jan., 2012 Scale: NTS
 Rev: 01 Drawn by :

Application: Expansion Joint Cover for Wall-to Wall / Ceiling to Ceiling



PROSPEC SPECIALTIES INC.
 3601 HIGHWAY 7, SUITE 400
 MARKHAM ON L3R 0M3, CANADA.
 Tel: (888) - 749 - 8456,
 Fax: (888) - 749 - 8455
 Email: info@prospecspecialties.com
 Web: prospecspecialties.com

Disclaimer: As Prospec Specialties' Policy is one of continual technical progress for the improvement of the company's services to its customers, the company reserves the right to modify the Designs of its products without notice.

FTS06 SYSTEM

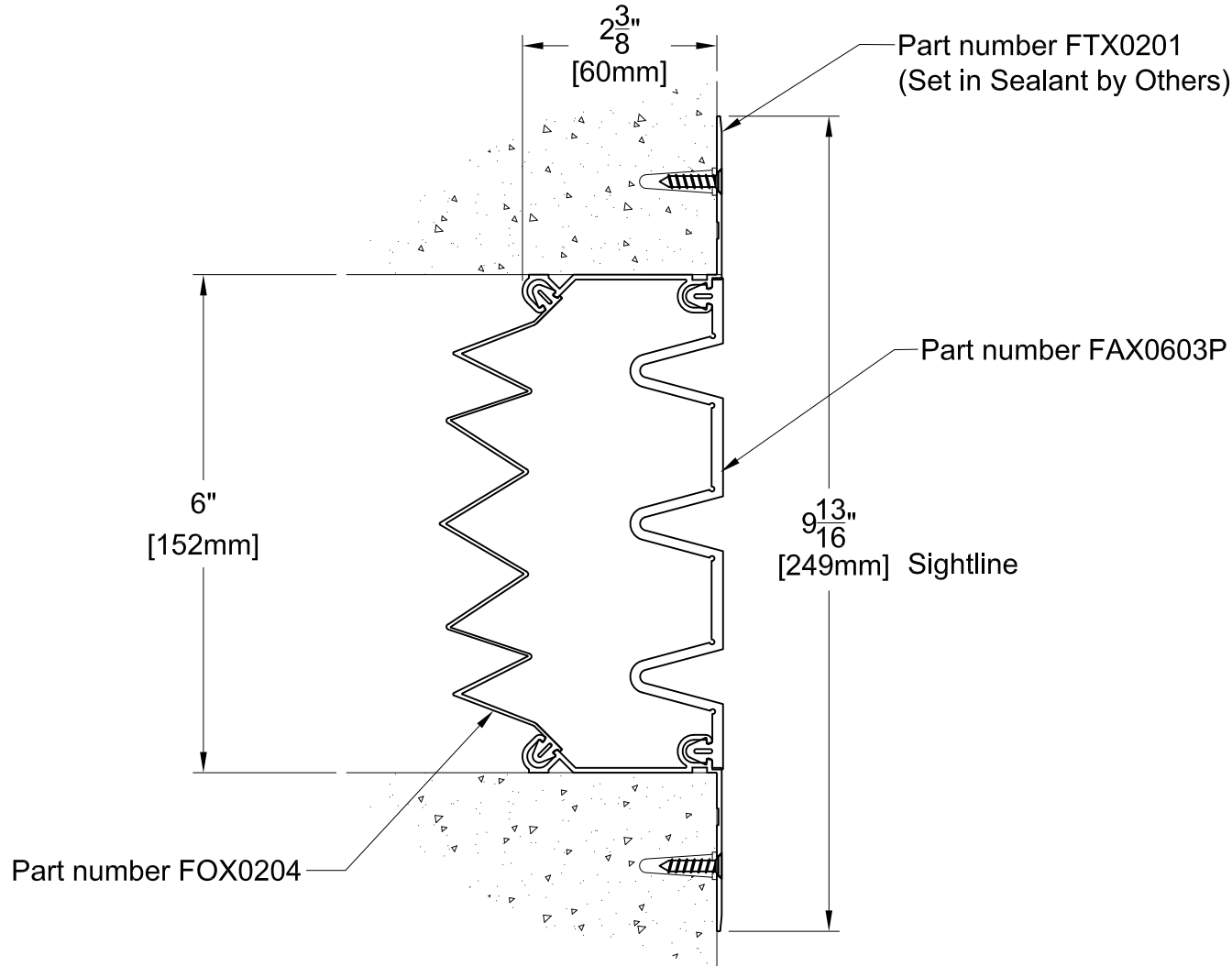

TECHNICAL DATA	IMPERIAL (in)	METRIC (mm)
Joint Width	6	152
Movement ± (Horizontal)	3"	76
Movement ± (Vertical)	3"	76

Date: Jan., 2012 Scale: NTS
 Rev: 01 Drawn by :

Application: Expansion Joint Cover for Wall-to Wall / Ceiling to Ceiling



PROSPEC SPECIALTIES INC.
 3601 HIGHWAY 7, SUITE 400
 MARKHAM ON L3R 0M3, CANADA.
 Tel: (888) - 749 - 8456,
 Fax: (888) - 749 - 8455
 Email: info@prospecspecialties.com
 Web: prospecspecialties.com

Disclaimer: As Prospec Specialties' Policy is one of continual technical progress for the improvement of the company's services to its customers, the company reserves the right to modify the Designs of its products without notice.