

BUS02 SYSTEM

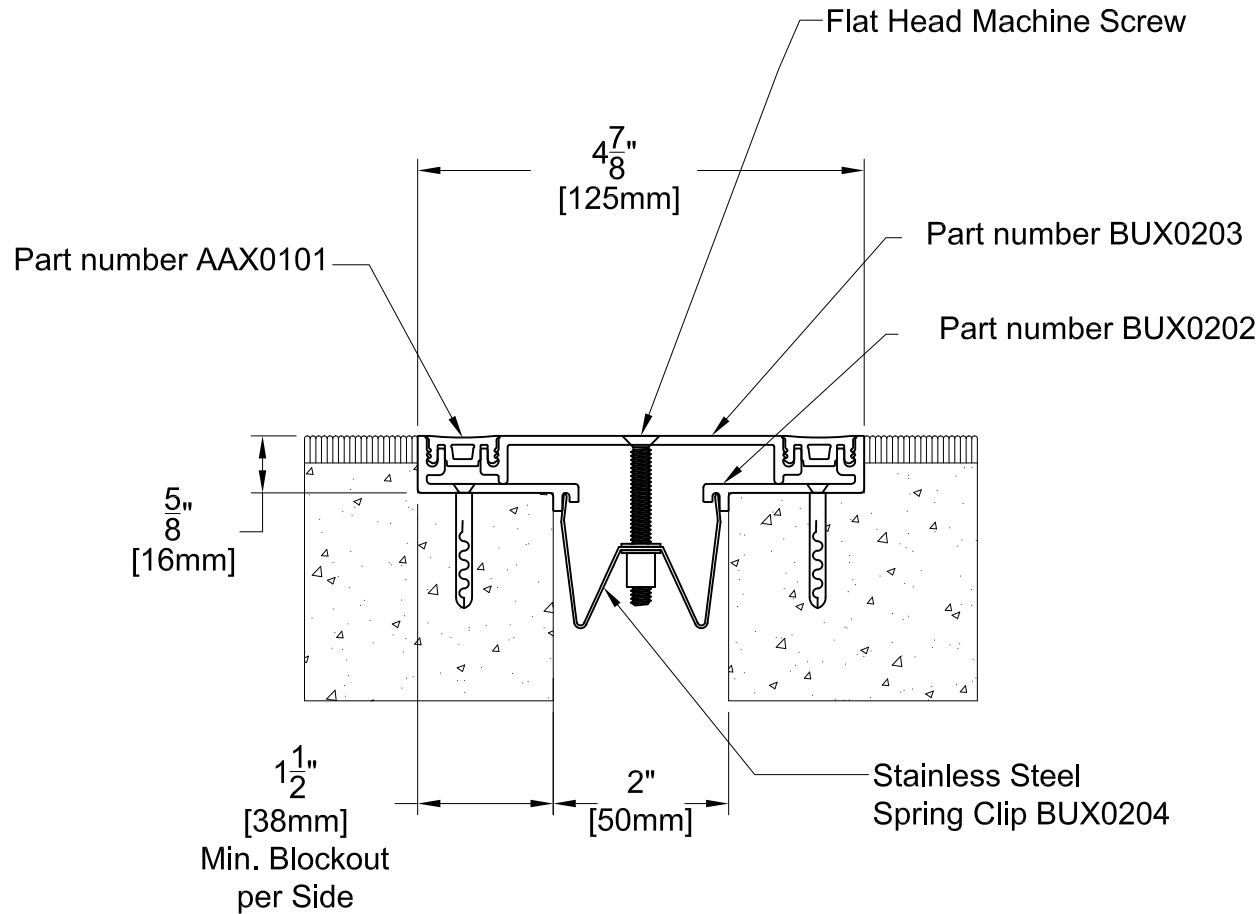

TECHNICAL DATA	IMPERIAL (inc)	METRIC (mm)
Joint Width	2"	51
Movement ± (Horizontal)	1/2"	13
Movement ± (Vertical)	1/2"	13
Load	3 (Tons)	
Date: Jan., 2012	Scale: NTS	
Rev:	Drawn by :	

APPLICATION: INTERNAL EXPANSION JOINT COVER FOR FLOOR TO FLOOR



PROSPEC SPECIALTIES INC.
 3601 HIGHWAY 7, SUITE 400
 MARKHAM ON L3R 0M3, CANADA.
 TEL: (888) - 749 - 8456,
 FAX: (888) - 749 - 8455
 Email: info@prospecspecialties.com
 Web: prospecspecialties.com

BUS04 SYSTEM

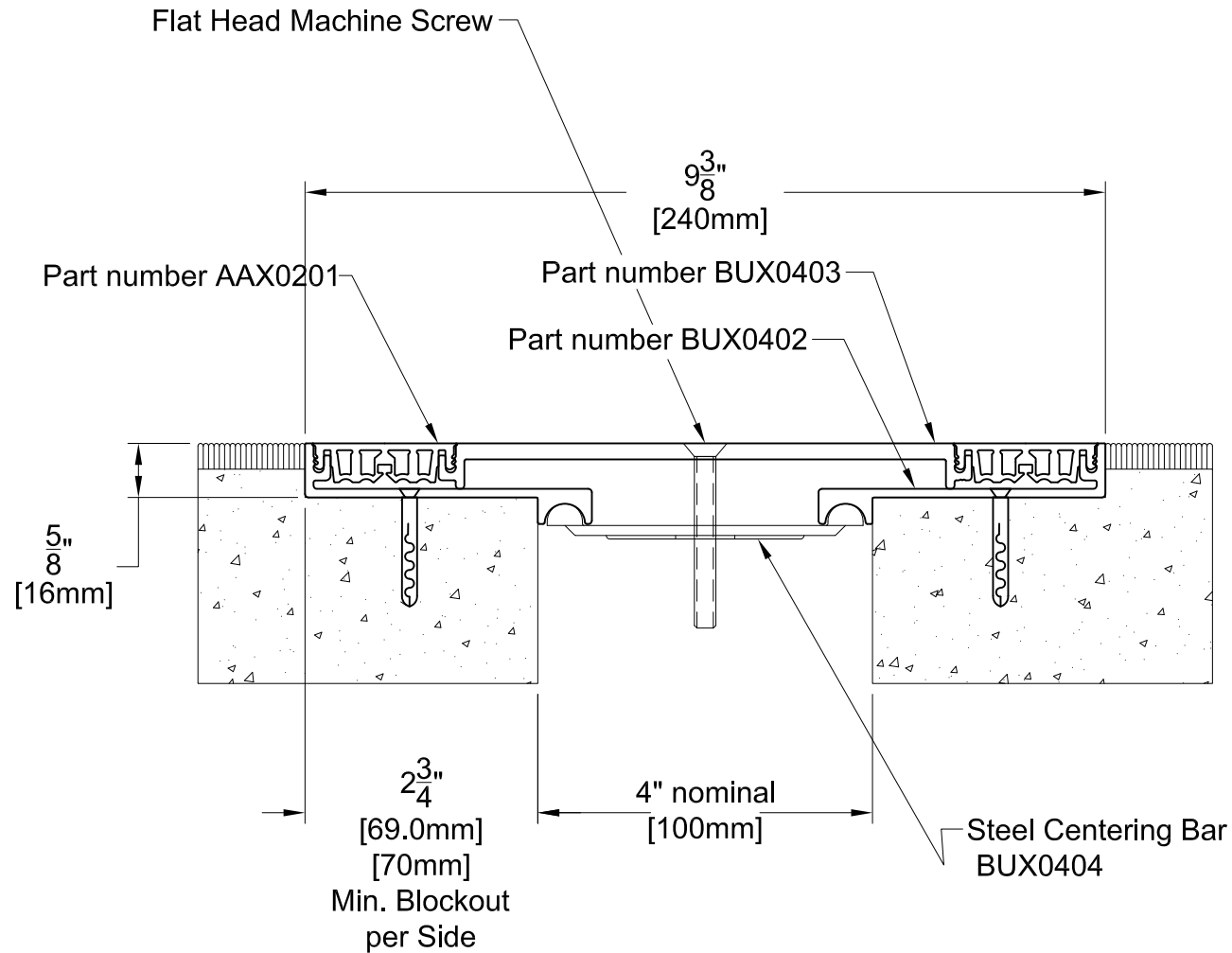

TECHNICAL DATA	IMPERIAL (inc)	METRIC (mm)
Joint Width	4"	102
Movement ± (Horizontal)	1"	25
Movement ± (Vertical)	1"	25
Load	2 (Tons)	
Date: Jan., 2012	Scale: NTS	
Rev:	Drawn by :	

APPLICATION: INTERNAL EXPANSION JOINT COVER FOR FLOOR TO FLOOR



PROSPEC SPECIALTIES INC.
 3601 HIGHWAY 7, SUITE 400
 MARKHAM ON L3R 0M3, CANADA.
 TEL: (888) - 749 - 8456,
 FAX: (888) - 749 - 8455
 Email: info@prospecspecialties.com
 Web: prospectspecialties.com

BUS06 SYSTEM

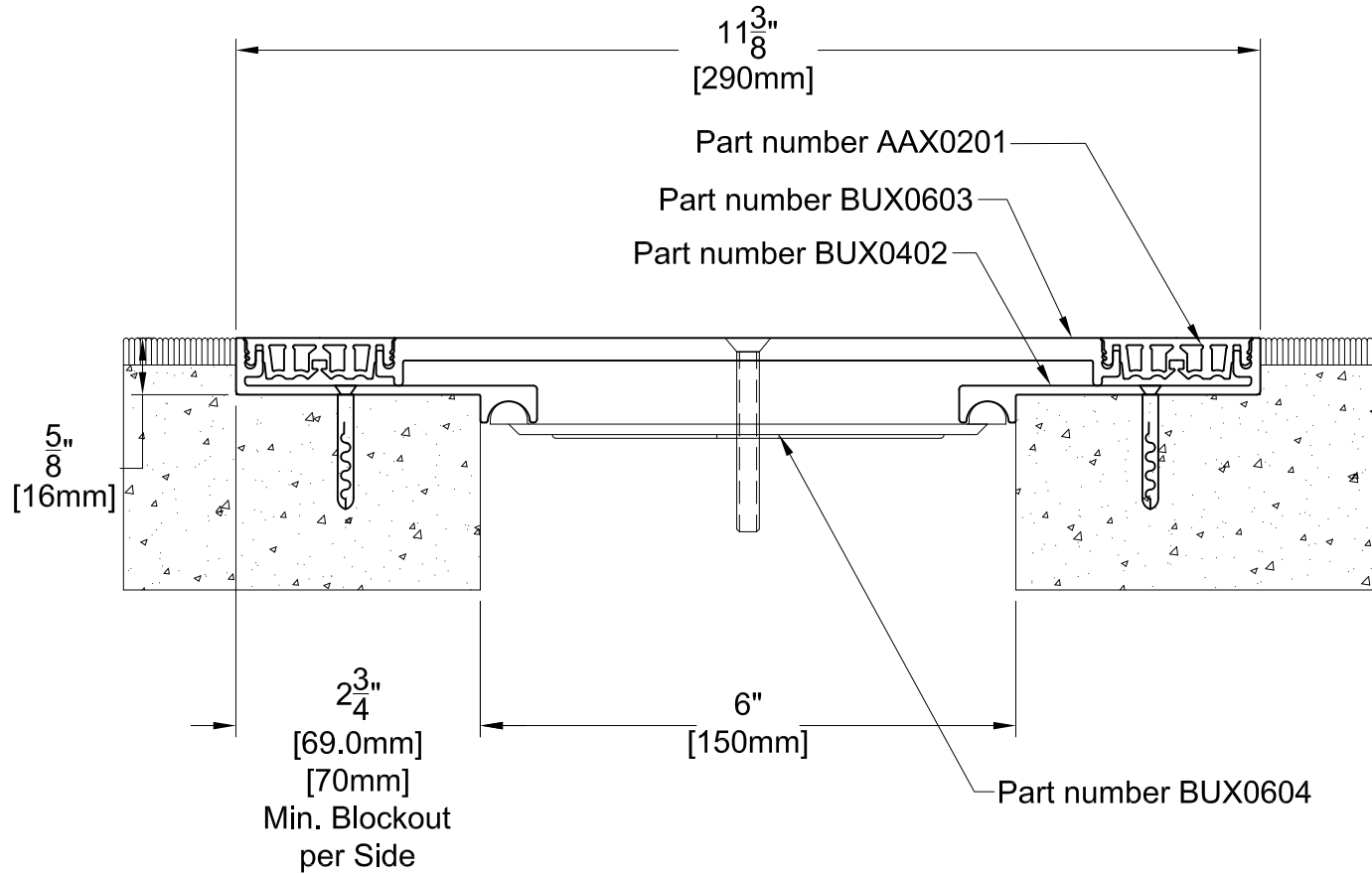

TECHNICAL DATA	IMPERIAL (inc)	METRIC (mm)
Joint Width	6"	150
Movement ± (Horizontal)	1-1/2"	38
Movement ± (Vertical)	1- 1/2"	38
Load	1 (Ton)	
Date: Jan., 2012	Scale: NTS	
Rev:	Drawn by :	

APPLICATION: INTERNAL EXPANSION JOINT
COVER FOR FLOOR TO FLOOR



PROSPEC SPECIALTIES INC.
3601 HIGHWAY 7, SUITE 400
MARKHAM ON L3R 0M3, CANADA.
TEL: (888) - 749 - 8456,
FAX: (888) - 749 - 8455
Email: info@prospecspecialties.com
Web: prospecspecialties.com

BUS08 SYSTEM

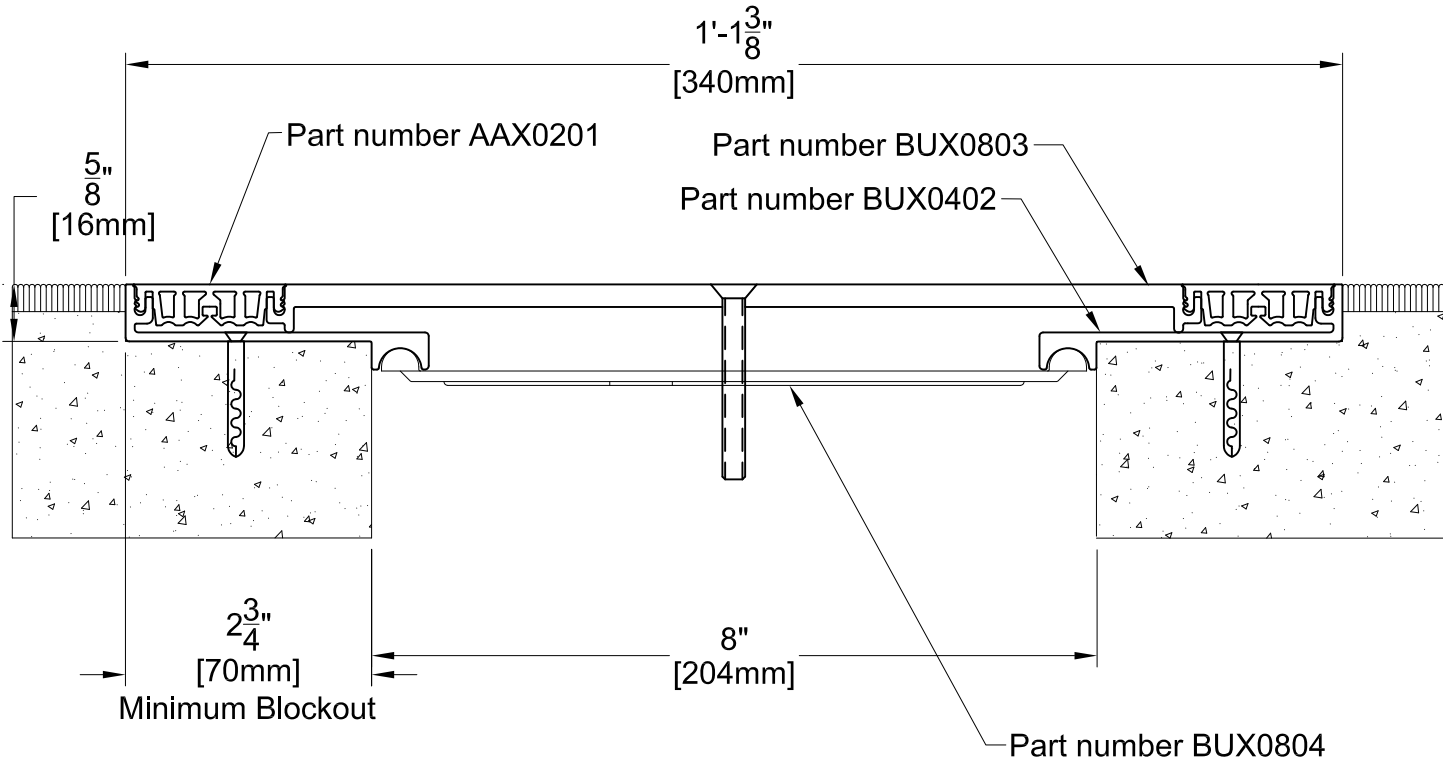

TECHNICAL DATA	IMPERIAL (inc)	METRIC (mm)
Joint Width	8"	200
Movement ± (Horizontal)	2"	50
Movement ± (Vertical)	2"	50
Load	1 (Ton)	
Date: Jan., 2012	Scale: NTS	
Rev:	Drawn by :	

APPLICATION: INTERNAL EXPANSION JOINT COVER FOR FLOOR TO FLOOR



PROSPEC SPECIALTIES INC.
 3601 HIGHWAY 7, SUITE 400
 MARKHAM ON L3R 0M3, CANADA.
 TEL: (888) - 749 - 8456,
 FAX: (888) - 749 - 8455
 Email: info@prospecspecialties.com
 Web: prospectspecialties.com