

# FAC01 SYSTEM

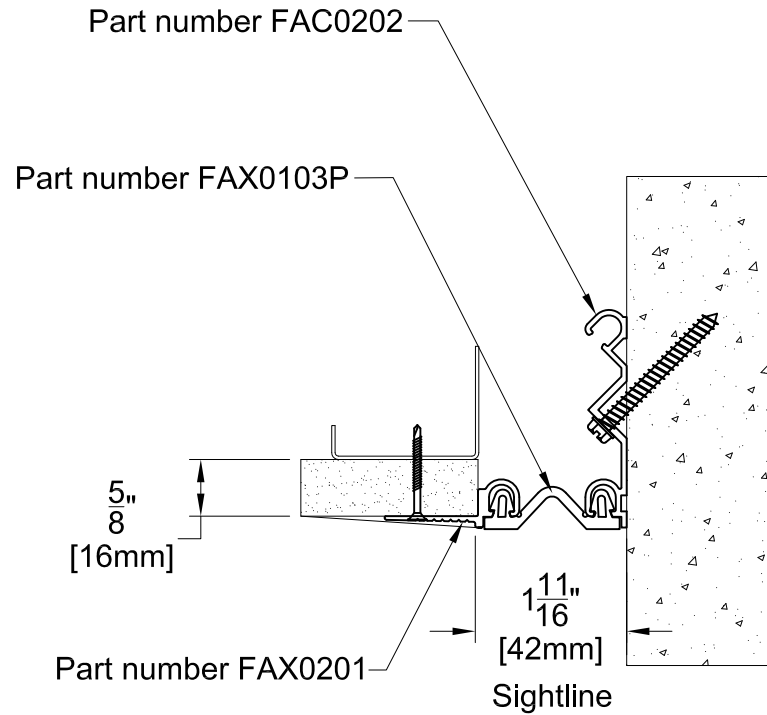

TECHNICAL DATA	IMPERIAL (in)	METRIC (mm)
Joint Width	1"	25
Movement ± (Horizontal)	1/2"	12 1/2
Movement ± (Vertical)	1/2"	12 1/2

Date: Jan., 2012      Scale: NTS

Rev:      Drawn by :

**Application:**  
Expansion Joint Cover for Wall Corner / Wall to Ceiling.



**PROSPEC SPECIALTIES INC.**  
3601 HIGHWAY 7, SUITE 400  
MARKHAM ON L3R 0M3, CANADA.  
Tel: (888) - 749 - 8456,  
Fax: (888) - 749 - 8455  
Email: [info@prospecspecialties.com](mailto:info@prospecspecialties.com)  
Web: [prospecspecialties.com](http://prospecspecialties.com)

**Disclaimer:** As Prospec Specialties' Policy is one of continual technical progress for the improvement of the company's services to its customers, the company reserves the right to modify the Designs of its products without notice.

# FAC02 SYSTEM

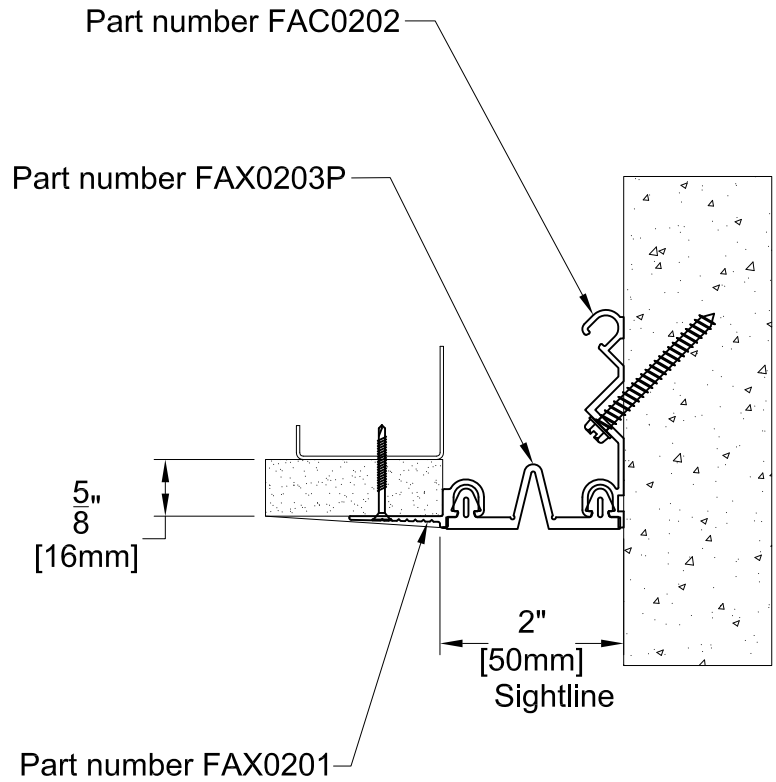

TECHNICAL DATA	IMPERIAL (in)	METRIC (mm)
Joint Width	2"	51
Movement ± (Horizontal)	1"	25
Movement ± (Vertical)	1"	25

Date: Jan., 2012      Scale: NTS

Rev: 01      Drawn by :

**Application:**  
Expansion Joint Cover for Wall Corner / Wall to Ceiling.



**PROSPEC SPECIALTIES INC.**  
3601 HIGHWAY 7, SUITE 400  
MARKHAM ON L3R 0M3, CANADA.  
Tel: (888) - 749 - 8456,  
Fax: (888) - 749 - 8455  
Email: [info@prospecspecialties.com](mailto:info@prospecspecialties.com)  
Web: [prospecspecialties.com](http://prospecspecialties.com)

**Disclaimer:** As Prospec Specialties' Policy is one of continual technical progress for the improvement of the company's services to its customers, the company reserves the right to modify the Designs of its products without notice.

# FAC03 SYSTEM

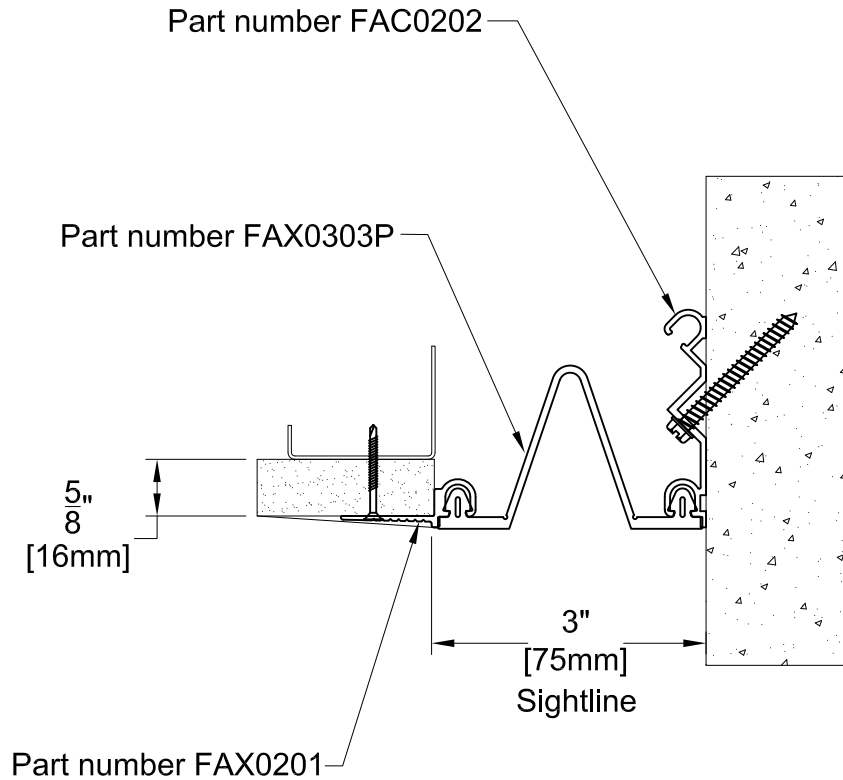

TECHNICAL DATA	IMPERIAL (in)	METRIC (mm)
Joint Width	3"	76
Movement ± (Horizontal)	1-1/2"	38
Movement ± (Vertical)	1-1/2"	38

Date: Jan., 2012	Scale: NTS
Rev: 01	Drawn by :

**Application:**  
Expansion Joint Cover for Wall Corner / Wall to Ceiling.



**PROSPEC SPECIALTIES INC.**  
3601 HIGHWAY 7, SUITE 400  
MARKHAM ON L3R 0M3, CANADA.  
Tel: (888) - 749 - 8456,  
Fax: (888) - 749 - 8455  
Email: [info@prospecspecialties.com](mailto:info@prospecspecialties.com)  
Web: [prospecspecialties.com](http://prospecspecialties.com)

**Disclaimer:** As Prospec Specialties' Policy is one of continual technical progress for the improvement of the company's services to its customers, the company reserves the right to modify the Designs of its products without notice.

# FAC04 SYSTEM

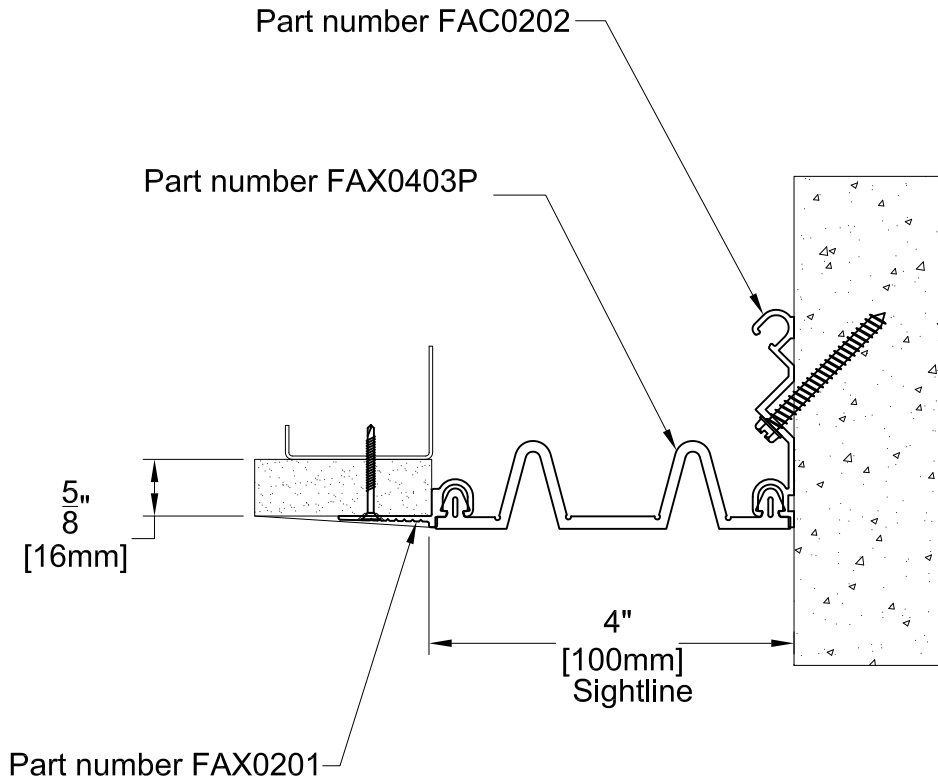

TECHNICAL DATA	IMPERIAL (in)	METRIC (mm)
Joint Width	4"	102
Movement ± (Horizontal)	2"	51
Movement ± (Vertical)	2"	51

Date: Jan., 2012	Scale: NTS
Rev: 01	Drawn by :

**Application:**  
Expansion Joint Cover for Wall Corner / Wall to Ceiling.



**PROSPEC SPECIALTIES INC.**  
3601 HIGHWAY 7, SUITE 400  
MARKHAM ON L3R 0M3, CANADA.  
Tel: (888) - 749 - 8456,  
Fax: (888) - 749 - 8455  
Email: [info@prospecspecialties.com](mailto:info@prospecspecialties.com)  
Web: [prospecspecialties.com](http://prospecspecialties.com)

**Disclaimer:** As Prospec Specialties' Policy is one of continual technical progress for the improvement of the company's services to its customers, the company reserves the right to modify the Designs of its products without notice.

# FAC06 SYSTEM

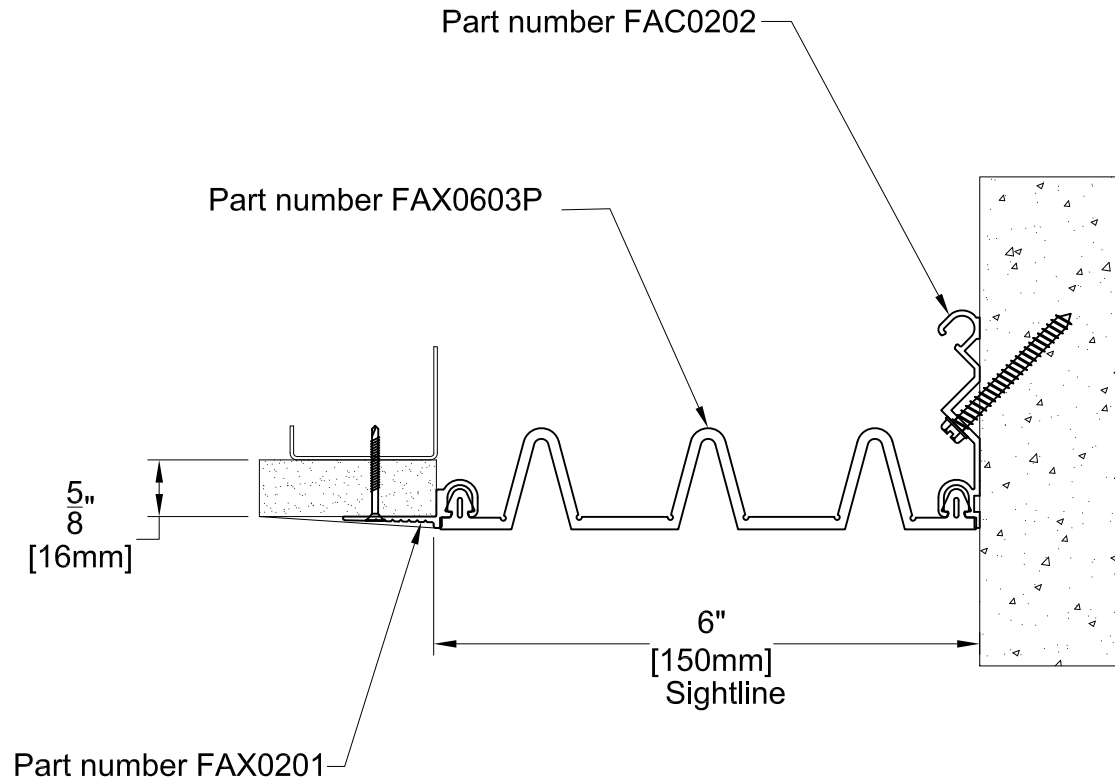

TECHNICAL DATA	IMPERIAL (in)	METRIC (mm)
Joint Width	6"	152
Movement ± (Horizontal)	3"	76
Movement ± (Vertical)	3"	76

Date: Jan., 2012	Scale: NTS
Rev: 01	Drawn by :

**Application:**  
Expansion Joint Cover for Wall Corner / Wall to Ceiling.



**PROSPEC SPECIALTIES INC.**  
3601 HIGHWAY 7, SUITE 400  
MARKHAM ON L3R 0M3, CANADA.  
Tel: (888) - 749 - 8456,  
Fax: (888) - 749 - 8455  
Email: [info@prospecspecialties.com](mailto:info@prospecspecialties.com)  
Web: [prospecspecialties.com](http://prospecspecialties.com)

**Disclaimer:** As Prospec Specialties' Policy is one of continual technical progress for the improvement of the company's services to its customers, the company reserves the right to modify the Designs of its products without notice.