

## CAC Series

Note: Verify that the structural gap and blockout dimension is in conformance with submittal data before beginning installation. If this is a Fire Rated Assembly, the fire barrier must be installed before the Architectural Joint System. Refer to the fire barrier instructions for specific system installation.

Fig. 1 (CAC Series, Floor Frame shown)

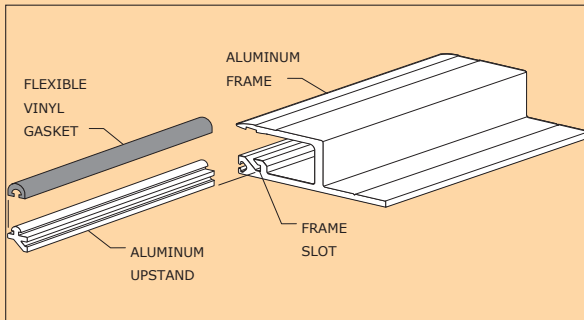
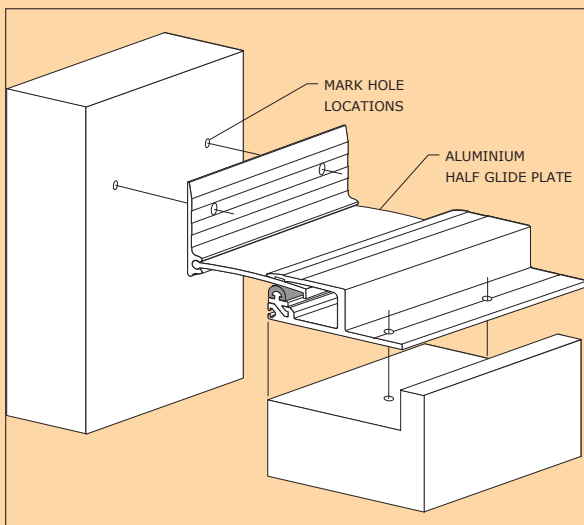

Fig. 2.



1. Install the architectural joint system on a level surface within the blockout. To determine blockout depth for the 'CAC' system, deduct thickness of floor finish from frame height. Make sure top of frame is level with the finished floor height. This may require adding leveling compound to raise the top of the frame.

Figure 1

2. Cut the aluminum components to the desired length.
3. Slide or press the flexible vinyl gasket onto the aluminium upstand.
4. Slide the aluminum upstand with gasket into the floor frame slot.  
NOTE: It may be necessary to apply silicone spray to the leg of the upstand prior to insertion.
5. Slide the ball end of the aluminum half glide plate into the socket channel of the wall frame.

Figure 2

6. Assemble the system by inserting the aluminum half glide plate into the space between the vinyl gasket and the underside of the floor frame.
7. Place the assembled system in the blockout so that the:
  - 7a. Floor frame does not extend over the edge of the structural gap.
  - 7b. Aluminum wall frame is firmly located against the finished wall.
  - 7c. Top of the aluminum half glide plate is horizontal.



Fig. 2a.

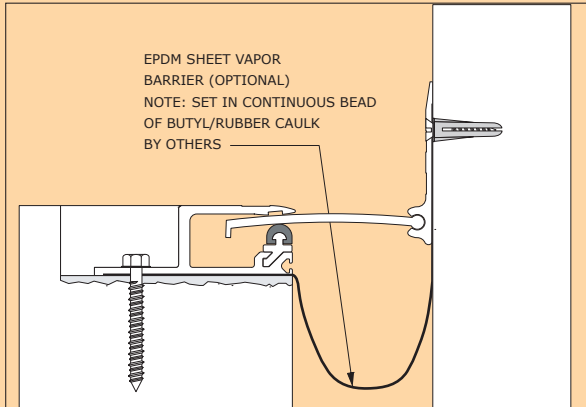

Fig. 3

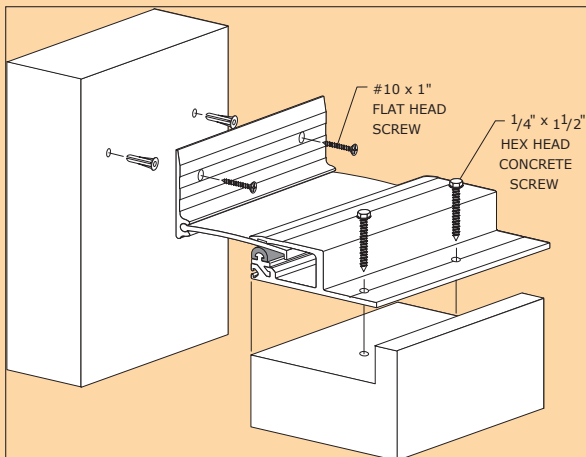
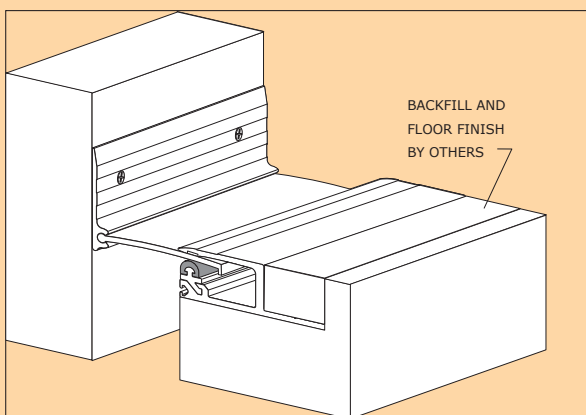

Fig. 4



8. Mark the pre-drilled hole locations on the blockout substrate and wall.

9. Remove the frame assembly from the blockout.

10. Drill all marked holes.

10a. For 'CAC' systems on the floor/blockout, use a 3/16" (5 mm) concrete drill bit and drill 1- 5/8" (42mm) deep. On the wall, use a 1/4" (6mm) drill bit and drill 1-1/8" (30mm) deep. Insert plastic plug anchors into wall holes.

10b. Optional EPDM Vapor Barrier: Lay continuous bead of butyl rubber caulk in the blockout and on the wall. Starting at one end of the frame assembly, place vapor barrier evenly in the blockout and wall allowing the excess material to drape into structural gap. If necessary, vapor barrier may be fastened to substrate with masonry nails. Fold ends up or weep out. (see Figure 2a).

11. Return the frame assembly into position over the drilled hole locations.

For 'CAC, system, secure the floor frame in place with one 1/4" x 1-1/2" hex head concrete screw for each hole. Secure the wall frame in place using one 1" flat head screw for each plastic plug.

Figure 4

12. Backfill the blockout with high strength non-shrink epoxy grout (installer furnished).

12a. On 'CAC' system, install the floor finish level to the top of the frame.

13. Clean the exposed surfaces with a non-solvent cleaner, as required.

